

WHISPER CUBE®

TB-0073

Number of panels: Foldable

Outside dimensions:
60 cm x 61 cm x 61 cm (L x H x D)

Acoustic environment:
N/A

Number of interpreters:



Standard outside color:
Light grey

Standard inside color:
Dark blue. Other colors available on request at an additional cost.

Assembly:
No tools required

Approximative assembly time:
10 minutes (2 persons)

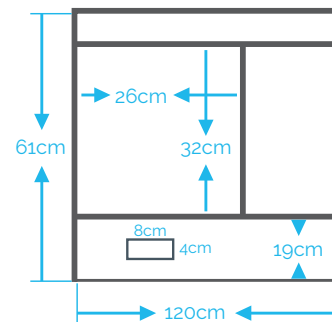
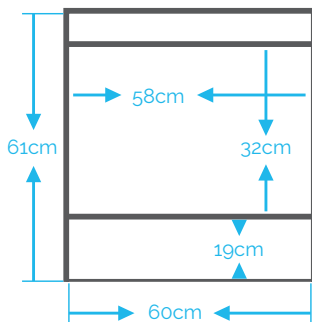

*Interior dimensions shown

AUTHORIZED DEALER:

iProbe Multilingual Solutions, Inc. | +1-212-489-6035 | info@iprobesolutions.com

iprobesolutions.com





Total packaging weight : 19,80 kg



Storage & Shipping:

Soft side carrying case
 Outside case dim. 69,5 cm x 69,5 cm x 17,3 cm
 (L x H x D)

Air ventilation:

Open back

Options:

Double Plexiglas®, ATA shipping case.

Construction

Each panel is built with exterior covering of expanded vinyl with special sound barrier of acoustic foam and MIL-B131-H laminating aluminium foil. The inside covering is made with decorative 100% polyester cotton 9 mm woven density, framing is high density PVC extrusion with unique connecting concept with industrial Velcro for easy assembly without tools.



PANELS	DIMENSIONS	WEIGHT
2 panels (portable)	60 cm x 61 cm x 61 cm	18 kg
TOTAL PANELS & CASES WEIGHT		19,80 kg

*Included 1 soft carrying case

AUTHORIZED DEALER:

iProbe Multilingual Solutions, Inc. | +1-212-489-6035 | info@iprobesolutions.com

iprobesolutions.com

