

CONGRESS®

ES-12-PB8005

Number of panels: 10

Outside dimensions:

166 cm x 203 cm x 166 cm (L x H x D)

Acoustic environment:

Surpass ISO-4043-1998 international standard

Number of interpreters:



Standard outside color:

Light grey (laminated finish)

Standard inside color:

Light grey

Assembly:

No tools required (new quick Latch® systems)

Approximative assembly time:

10 minutes (2 persons)

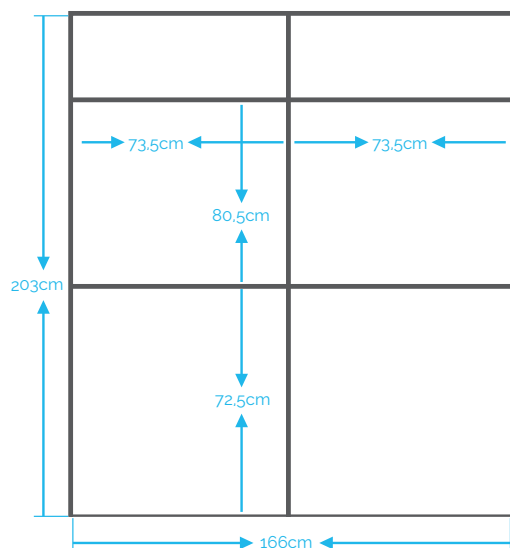
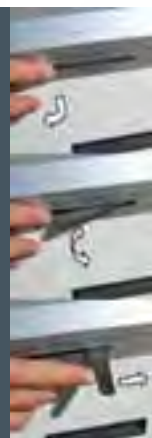

NEW
Aluminium frame

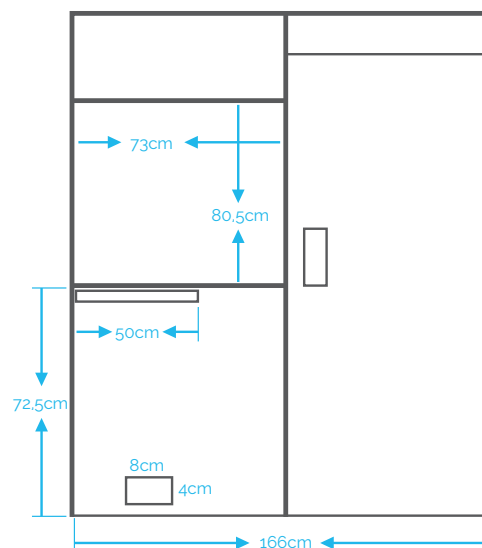
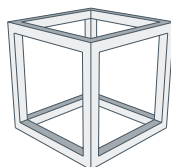

*Interior dimensions shown

AUTHORIZED DEALER:

iProbe Multilingual Solutions, Inc. | +1-212-489-6035 | info@iprobesolutions.com

iprobesolutions.com





Total packaging weight : 208 kg

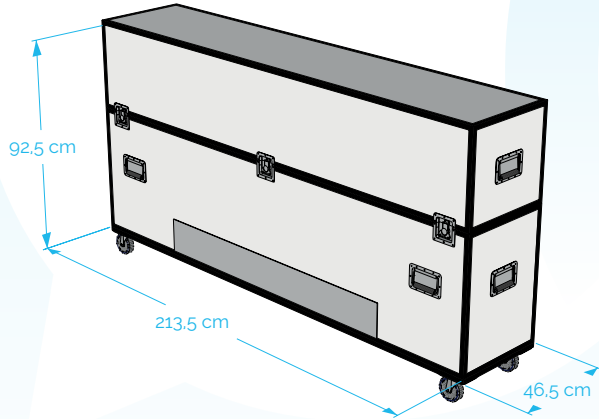

Storage & Shipping:

Included (1) ATA-300 shipping cases on wheels (68,5 kg for 1 case).

Outside case dim. 213,5 cm x 92,5 cm x 46,45 cm (L x H x D)

Air ventilation:

Included (2) 38 DB silent whisper 110 or 220 volts fan assembly units CSA approved.



Options:

Easy to install working table, double Plexiglas® windows, air conditioning, soundproof flooring, interior partition systems, custom size built.

Construction

Each panel is built with laminate finish exterior with special isolated soundproof fiberglass panel. Material is fire retardant UL-723. Inside covering is made with decorative textile 100% polyester. Cotton of 9 mm. Woven density and weight of 60 gr. per meter. Framing is aluminium extrusion with unique latching systems for easy assembly without tools.



PANELS	DIMENSIONS	WEIGHT
Standard panels (3)	82,3 cm x 201 cm	13,60 kg
Window panels (4)	82,3 cm x 201 cm	15,20 kg
Door panel (1)	82,3 cm x 201 cm	18,50 kg
Roof panels (2)	84 cm x 163,6 cm	9,90 kg
TOTAL PANELS WEIGHT		139,90 kg
TOTAL PANELS & CASES WEIGHT		208,00 kg

*Included 1 flight case & 2 fans

*Table is optional

*Door panel may be installed on both sides or in the back

AUTHORIZED DEALER:

iProbe Multilingual Solutions, Inc. | +1-212-489-6035 | info@iprobesolutions.com

iprobesolutions.com

